

REVISIONS				
REV.	DESCRIPTION	DATE	ECN	INITIAL
A	INITIAL RELEASE	03/05/21	3794	FCG

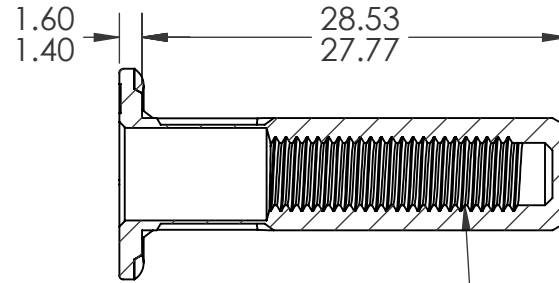
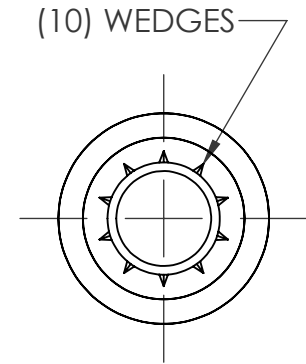
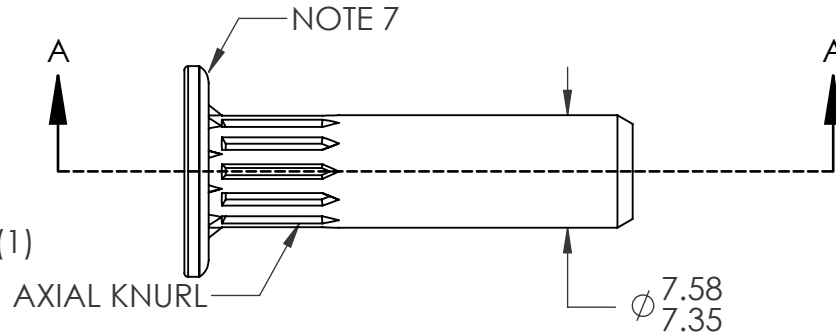
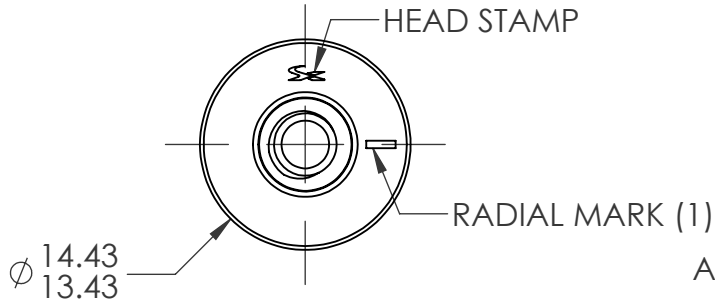

M4x0.7 6H
PER ASME B1.13M
MINOR DIA.: 3.25 - 3.42

NOTE:

- GRIP RANGE: .3.0 - 5.5
- HOLE SIZE: 7.60 +0.15/-0.00 AFTER ALL APPLIED FINISHES.
- INSTALLED LENGTH: 21.65 MAX.
- INSTALLED THREAD DEPTH: 20.0 MIN. IN MIN. GRIP
- LUBRICATION: WAX
- INSTALLATION TOOL: SPIN-PULL
- DEPOSIT PLASTISOL ALONG OUTER GROOVE OF THE HEAD. SEAL MUST NOT CONTACT WEDGES.

PROPRIETARY AND CONFIDENTIAL

THIS DRAWING, AND THE INFORMATION CONTAINED HEREIN, ARE THE PROPERTY OF SHEREX AND ARE NOT TO BE USED IN ANY MANNER DETRIMENTAL TO THE INTEREST OF THE COMPANY.
SHEREX SOLUTIONS RESERVES THE RIGHT TO REVISE PART/DRAWING WITHOUT NOTICE.

		UNLESS OTHERWISE SPECIFIED:		NAME	DATE
		DIMENSIONS ARE IN MILLIMETERS TOLERANCES: ANGULAR: MACH ± 1 BEND ± 1 ONE PLACE DECIMAL $\pm .3$ TWO PLACE DECIMAL $\pm .08$	DRAWN	FCG	03/05/21
		INTERPRET GEOMETRIC TOLERANCING PER: ASME Y14.5M-1994	CHECKED		
		MATERIAL C1008/C1010	ENG APPR.	CL	03/05/21
		FINISH ZINC PLATE CLEAR TRIVALENT CHROMATE PER SFS-01-001, SC1	MFG APPR.		
NEXT ASSY	USED ON		Q.A.		
APPLICATION		DO NOT SCALE DRAWING	COMMENTS: E-mail: info@sherex.com www.sherex.com Phone: 866-474-3739 Fax: 716-875-0358		



TITLE:

M4X0.7 LARGE FLANGE
CLOSED END OPTISERT W/ SEAL

SIZE DWG. NO.

A OPT2-470-5.5BS

REV

A

SCALE: 2:1 WEIGHT:

SHEET 1 OF 1