

REVISIONS				
REV.	DESCRIPTION	DATE	ECN	INITIAL
A	INITIAL RELEASE	1/21/21	3764	ARG

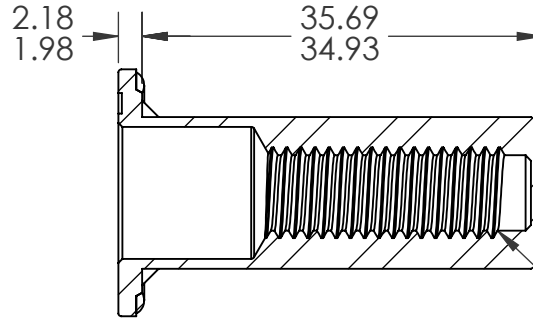
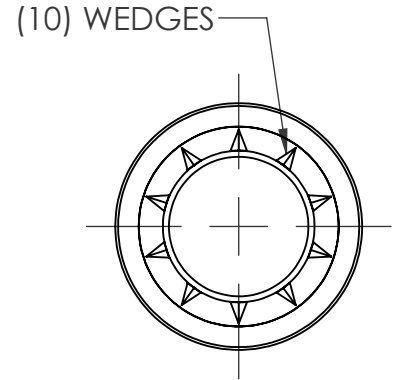
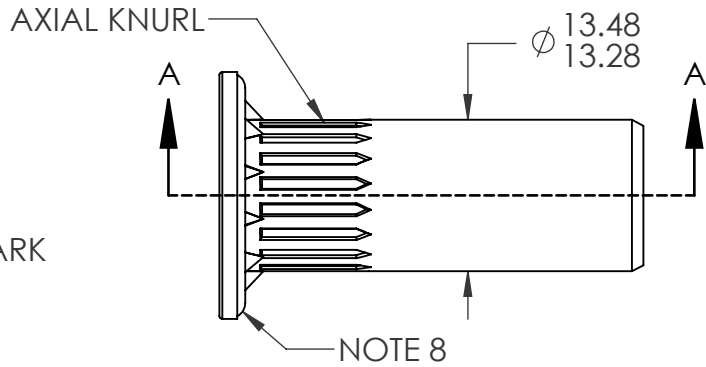
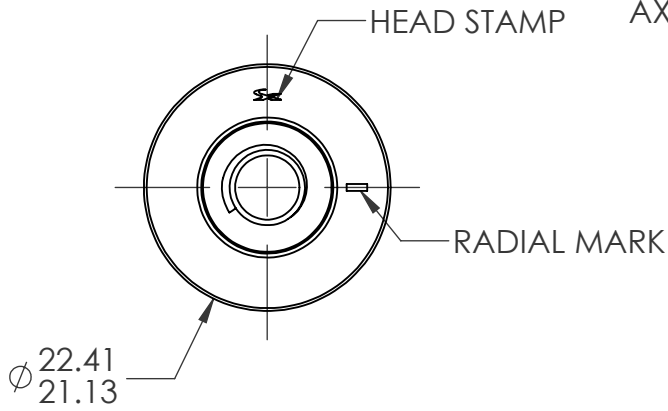

M8X1.25 6H
PER ASME B1.13M
MINOR DIA.: 6.65 - 6.91

SECTION A-A
SCALE 1.5 : 1

- NOTE:**
- GRIP RANGE: 3.5 - 6.0
 - HOLE SIZE: 13.50 +0.15/-0.00 AFTER ALL APPLIED FINISHES.
 - INSTALLED LENGTH: 27.50 MAX.
 - INSTALLED THREAD DEPTH: 27.0 MIN. IN MIN. GRIP
 - LUBRICATION: WAX
 - INSTALLATION TOOL: SPIN-PULL
 - THREADS MEET CLASS 8 PROOF LOAD: 31.8kN PER ISO 898-2
 - DEPOSIT PLASTISOL ALONG OUTER GROOVE OF THE HEAD. SEAL MUST NOT CONTACT WEDGES.

PROPRIETARY AND CONFIDENTIAL
THIS DRAWING, AND THE INFORMATION CONTAINED HEREIN, ARE THE PROPERTY OF SHEREX AND ARE NOT TO BE USED IN ANY MANNER DETRIMENTAL TO THE INTEREST OF THE COMPANY.
SHEREX SOLUTIONS RESERVES THE RIGHT TO REVISE PART/DRAWING WITHOUT NOTICE.

		UNLESS OTHERWISE SPECIFIED:	NAME	DATE
		DIMENSIONS ARE IN MILLIMETERS TOLERANCES: ANGULAR: MACH ± 1 BEND ± 1 ONE PLACE DECIMAL ± 0.3 TWO PLACE DECIMAL ± 0.08	DRAWN	ARG 1/21/21
		INTERPRET GEOMETRIC TOLERANCING PER: ASME Y14.5M-1994	CHECKED	
		MATERIAL	ENG APPR.	CL 1/21/21
		C1008/C1010 STEEL	MFG APPR.	
		FINISH	Q.A.	
		ZINC PLATE CLEAR TRIVALENT CHROMATE PER SFS-01-001, SC1	COMMENTS: E-mail: info@sherex.com www.sherex.com Phone: 866-474-3739 Fax: 716-875-0358	
NEXT ASSY	USED ON			
APPLICATION		DO NOT SCALE DRAWING		



TITLE:
M8 CLOSED END LARGE FLANGE OPTISERT W/ SEAL

SIZE DWG. NO. REV
A OPT2-8125-6.0BS A

SCALE: 2:1 WEIGHT: SHEET 1 OF 1