

REVISIONS				
REV.	DESCRIPTION	DATE	ECN	INITIAL
A	INITIAL RELEASE	2/3/21	3698	MTB
B	UPDATE BODY DIAMETER	09/07/22	4105	MRA

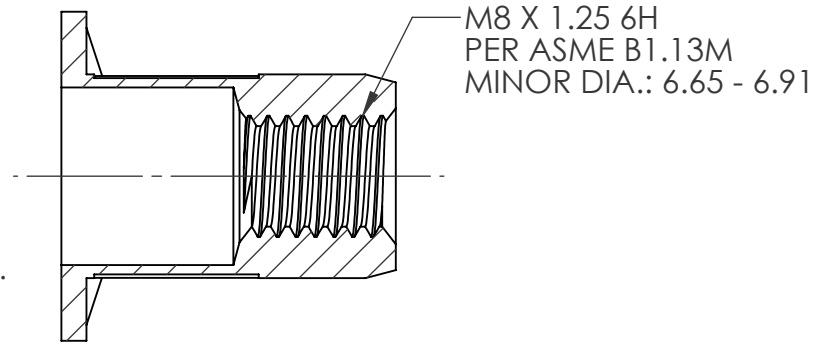
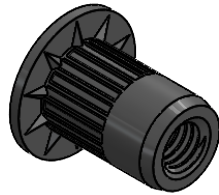
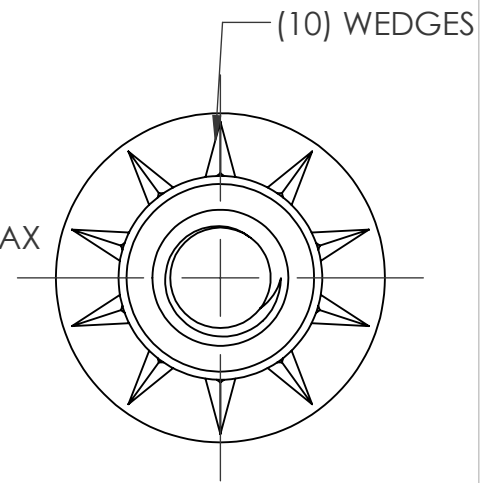
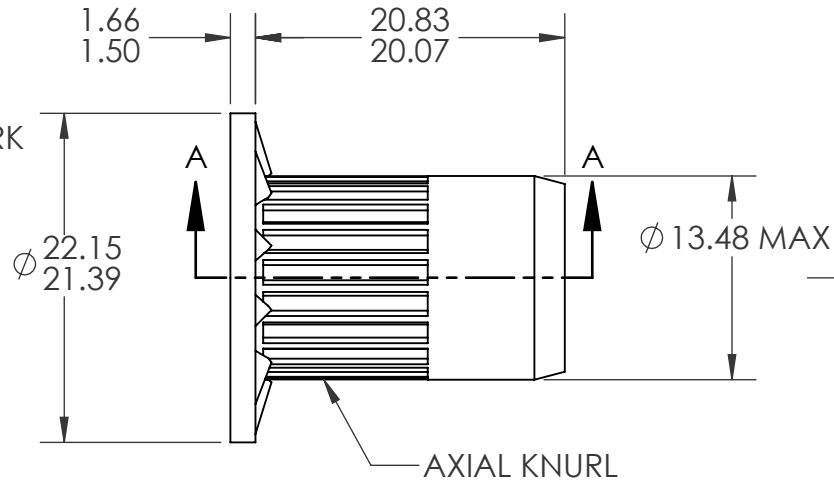
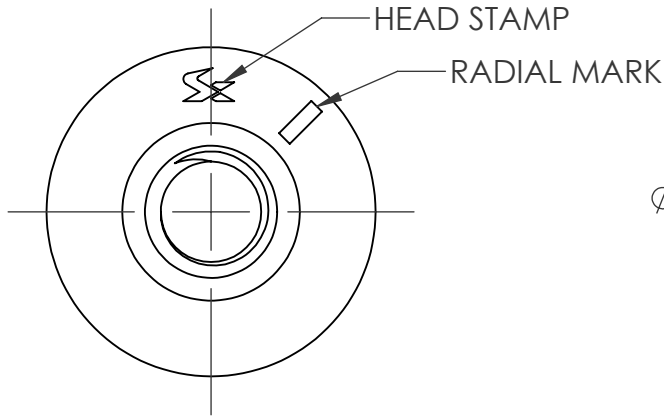

SECTION A-A

NOTE:

- GRIP RANGE: 3.5 - 6.0
- HOLE SIZE: 13.50 +0.15/-0.00 AFTER ALL APPLIED FINISHES.
- INSTALLED LENGTH: 12.5 MAX.
- LUBRICATION: NONE
- INSTALLATION TOOL: SPIN-PULL
- THREADS MEET CLASS 8 PROOF LOAD: 31.8kN PER ISO 898-2

**PROPRIETARY AND CONFIDENTIAL**

THIS DRAWING, AND THE INFORMATION CONTAINED HEREIN, ARE THE PROPERTY OF SHEREX AND ARE NOT TO BE USED IN ANY MANNER DETRIMENTAL TO THE INTEREST OF THE COMPANY.  
SHEREX SOLUTIONS RESERVES THE RIGHT TO REVISE PART/DRAWING WITHOUT NOTICE.  
UNLESS OTHERWISE SPECIFIED, ALL SPECIFICATIONS REFERENCED ON THIS DRAWING WILL PERTAIN TO THE MOST RECENT AND ACTIVE REVISION.

		UNLESS OTHERWISE SPECIFIED:		NAME	DATE
		DIMENSIONS ARE IN MILLIMETERS TOLERANCES: ANGULAR: MACH ± 1 BEND ± 1 ONE PLACE DECIMAL ± 0.3 TWO PLACE DECIMAL ± 0.08	DRAWN	MTB	2/3/21
		INTERPRET GEOMETRIC TOLERANCING PER: ASME Y14.5M-1994	CHECKED		
		MATERIAL	ENG APPR.	CL	2/3/21
		C1008/C1010 STEEL	MFG APPR.		
		FINISH	Q.A.		
		ZINC PLATE CLEAR TRIVALENT CHROMATE PER SFS-01-001, SC1	COMMENTS:	E-mail: info@sherex.com www.sherex.com Phone: 866-474-3739 Fax: 716-875-0358	
NEXT ASSY	USED ON				
APPLICATION		DO NOT SCALE DRAWING			



TITLE:

M8 OPEN END LARGE FLANGE OPTISERT

SIZE DWG. NO.

**A** OPT2-8125-6.0

REV

**B**

SCALE: 2:1 WEIGHT:

SHEET 1 OF 1